

EX KNIFE GATE VALVE

The EX model knife gate valve is a wafer type valve designed for general industrial service applications. The design of the body and seat assures non-clogging shut off on suspended solids in a wide range of industries such as Pulp & Paper, Wastewater Treatment Plants, Food & Beverage, Mining, Power Plants, Chemical Plants, Bulk Handling, etc.

Product description:

- Uni-directional wafer type knife gate valve
- Size range of DN50-1200 (larger sizes upon request). See Dimension Charts for pressure rating
- Rising & non-rising stem configurations available
- Standard flange connection: DIN PN10 (EN 1092-2) and ANSI B16.5 (class 150) Others available upon request
- Manual (handwheel, chainwheel, lever and bevel gear), pneumatic (single and double-acting), electric and hydraulic actuation options available
- Directives: 2006/42/EC (MACHINES), 2014/68/EU (PED) Fluid: Group 1 (b), 2 (Cat. 1. mod. A) and 2014/34/EU (ATEX)
- Certification EN 14432: 2014 tanks for the transport of dangerous goods (under request)

Features:

- Wafer cast monoblock body with internal cast-in gate wedges and guides for tighter shut-off
- Full port design for greater flow capacity and minimal pressure drop
- Stainless steel gate polished both sides to avoid jamming and seat damage
- Standard EPDM resilient seat. Metal-to-metal seat, as well as high performance rings and deflection cones available
- Long life PTFE impregnated synthetic fibre plus EPDM o-ring packing with easy access and adjustable gland follower. Wide range of packing materials available
- RAL-5015 blue epoxy-coating on all cast iron/carbon steel components
- Automated valves provided with gate guards in accordance with EU Safety Standards
- Other options: bonnets, V-ports, flush ports, special materials, fabricated valves, etc.
- Actuation accessories: limit & proximity switches, mechanical stops, positioners, solenoid valves, manual overrides, locking devices, fail safe systems, stem extensions and floor stands

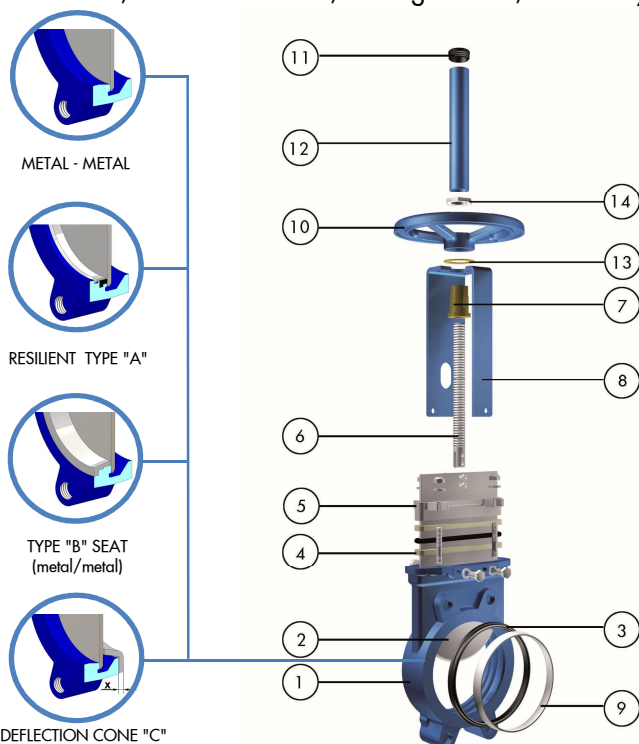

STANDARD PARTS LIST

Part	Cast Iron/ Stainless Steel
1 Body	GJL250(GG25) / CF8M
2 Gate	AISI 304 / AISI 316
3 Seat	Metal-to-Metal, EPDM
4 Packing	PTFE impreg. synth. fibre with EPDM o-ring
5 Gland Follower	Al (DN50-300) - Ductile Iron (DN350-1200) / CF8M
6 Stem	Stainless Steel
7 Stem Nut	Brass
8 Yoke	Epoxy-coated carbon steel
9 "A" ring	AISI 304 / AISI 316
10 Handwheel	GJS400 (GGG40)
11 Cap	Plastic
12 Stem Protector	Epoxy-coated carbon steel
13 Friction Washer	Brass
14 Nut	Zinc-plated carbon steel

DIMENSIONS (mm) Handwheel Rising Stem

DN	Working pressure	A	B	C	D	E	F	ØG	H	Weight (kg.)
50	10 bar	40	119	100	105	129	47	225	420	7
65	10 bar	40	134	100	115	146	47	225	450	8
80	10 bar	50	149	100	124	162	47	225	475	9
100	10 bar	50	169	100	140	187	47	225	520	11
125	10 bar	50	180	100	150	211	47	225	600	15
150	10 bar	60	210	100	175	237	47	225	652	18
200	10 bar	60	262	119	205	309	67	310	822	30
250	10 bar	70	318	122	250	364	67	310	1022	44
300	6 bar	70	372	122	300	414	67	310	1122	58
350	6 bar	96	431	197	338	486	66	410	1323	96
400	6 bar	100	486	197	392	536	66	410	1427	124
450	5 bar	106	540	201	432	588	66	550	1594	168
500	4 bar	110	602	201	485	648	66	550	1707	192
600	4 bar	110	708	201	590	748	66	550	2022	245
700	2 bar	110	834	380	686	890	74	800	2778	405
750	2 bar	110	884	380	760	945	74	800	2900	455
800	2 bar	110	1015	320	791	989	74	800	2980	512
900	2 bar	110	1040	320	895	1118	74	800	3215	680
1000	2 bar	110	1146	320	975	1220	74	800	3400	865

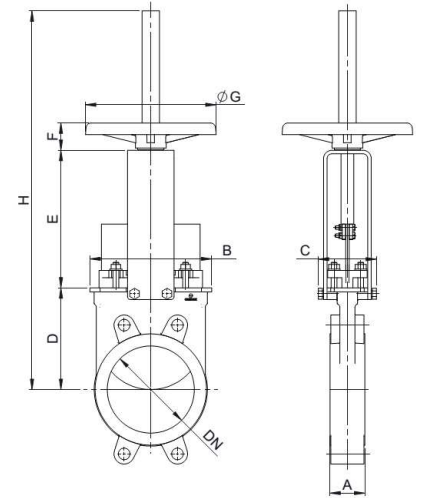

DIMENSIONS (mm) Handwheel Non Rising Stem

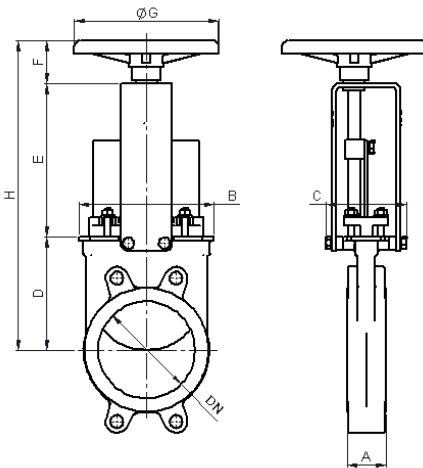

DN	Working pressure	A	B	C	D	E	F	ØG	H	Weight (kg.)
50	10 bar	40	119	125	105	144	63	225	312	7
65	10 bar	40	134	125	115	161	63	225	339	8
80	10 bar	50	149	125	124	177	63	225	364	9
100	10 bar	50	169	125	140	202	63	225	405	11
125	10 bar	50	180	125	150	226	63	225	439	15
150	10 bar	60	210	125	175	252	63	225	490	18
200	10 bar	60	262	142	205	317	73	310	595	30
250	10 bar	70	318	142	250	372	73	310	695	44
300	6 bar	70	372	142	300	422	73	310	795	58
350	6 bar	96	431	197	338	509	98	410	945	96
400	6 bar	100	486	197	392	559	98	410	1049	124
450	5 bar	106	540	201	432	611	98	550	1141	168
500	4 bar	110	602	201	485	671	98	550	1254	192
600	4 bar	110	708	201	590	771	98	550	1459	245
700	2 bar	110	834	380	686	900	151	800	1737	405
750	2 bar	110	884	380	760	945	151	800	1856	455
800	2 bar	110	1015	320	791	997	151	800	1939	512
900	2 bar	110	1040	320	895	1128	151	800	2174	680
1000	2 bar	110	1146	320	975	1255	151	800	2381	865

DIMENSIONS (mm) Pneumatic Actuator (D/A)

DN	Working pressure	A	B	C	D	E	F	G	H	Weight (kg.)	Standard Cyl.	Connect.
50	10 bar	40	119	100	105	129	178	115	412	9	C100/62	1/4" G
65	10 bar	40	134	100	115	146	193	115	454	10	C100/77	1/4" G
80	10 bar	50	149	100	124	162	211	115	497	11	C100/95	1/4" G
100	10 bar	50	169	100	140	187	231	115	558	14	C100/115	1/4" G
125	10 bar	50	180	100	150	211	271	140	632	20	C125/143	1/4" G
150	10 bar	60	210	100	175	237	296	140	708	25	C125/168	1/4" G
200	10 bar	60	262	119	205	309	358	175	872	44	C160/220	1/4" G
250	10 bar	70	318	122	250	364	428	220	1042	67	C200/270	3/8" G
300	6 bar	70	372	122	300	414	478	220	1192	82	C200/320	3/8" G
350	6 bar	96	431	197	338	500	549	277	1387	135	C250/375	3/8" G
400	6 bar	100	486	197	392	550	599	277	1541	165	C250/425	3/8" G
450	5 bar	106	540	270	432	598	680	382	1710	220	C300/475	1/2" G
500	4 bar	110	602	270	485	658	730	382	1873	280	C300/525	1/2" G
600	4 bar	110	708	270	590	758	830	382	2178	330	C300/625	1/2" G
700	2 bar	110	834	380	686	875	985	444	2546	520	C350/730	3/4" G
750	2 bar	110	884	380	760	930	1035	444	2725	585	C350/780	3/4" G
800	2 bar	110	1015	320	791	974	1085	444	2850	650	C350/830	3/4" G
900	2 bar	110	1040	320	895	1105	1202	515	3202	850	C400/930	3/4" G
1000	2 bar	110	1146	320	975	1217	1296	515	3488	1060	C400/1030	3/4" G

